

Introduction

► Feature

- Lifting capacity: 1,100 kg at 50Hz wire rope top layer
- Lifting height: 97 m
- Lifting speed: 4P: 14-25 m/min at 50Hz ; 6P: 9.2-16.4 m/min at 50Hz
- Brake: Electromagnetic spring-applied failsafe brake
- Control; Pendant switch powers the winch

► Unpacking

- Winch assembly 1pc
- Wire rope 12 mm x 100 m w/safety hook 1pc
- Low voltage control ass'y LV-320 1pc
- Pendant switch CPB-161 w/cord 1.25 mm² x 3C x 3 m 1pc

► Read this manual carefully

You should carefully read and understand this manual before operating it. Careless winch operation may result in personal injury hazards or property damage.

► Information requesting or parts ordering

Please specify the followings information:

- Winch PN
- Serial number
- Part description
- Replacement part number
- Quantity for each part

Installation

Before using the winch, make sure all electrical components have no corrosion or damaged; the environment should be clear and dry.

► Performance

Winch Model		CWG-30565										
Motor	kw x p	5.5 x 4					3.8 x 6					
Recommend Wire Rope	Size(mm)	12.0					12.0					
	Breaking (kg)	6,680					6,680					
1 st Layer	Rated Load (kg)	50Hz	1,968	2 nd Layer	Rated Load (kg)	50Hz	1,700	3 rd Layer	Rated Load (kg)	50Hz	1,496	
	Speed (m/min)	50Hz	4P		14	50Hz	4P		16.2	50Hz	4P	18.4
			6P		9.2		6P		10.6		6P	12.1
Rope-Winding Cumulating Sum (m)		12		Rope-Winding Cumulating Sum (m)		26		Rope-Winding Cumulating Sum (m)		42		
4 th Layer	Rated Load (kg)	50Hz	1,336	5 th Layer	Rated Load (kg)	50Hz	1,207	6 th Layer	Rated Load (kg)	50Hz	1,100	
	Speed (m/min)	50Hz	4P		20.6	50Hz	4P		22.8	50Hz	4P	25
			6P		13.5		6P		15.0		6P	16.4
Rope-Winding Cumulating Sum (m)		59		Rope-Winding Cumulating Sum (m)		79		Rope-Winding Cumulating Sum (m)		100		

► Wiring Diagram

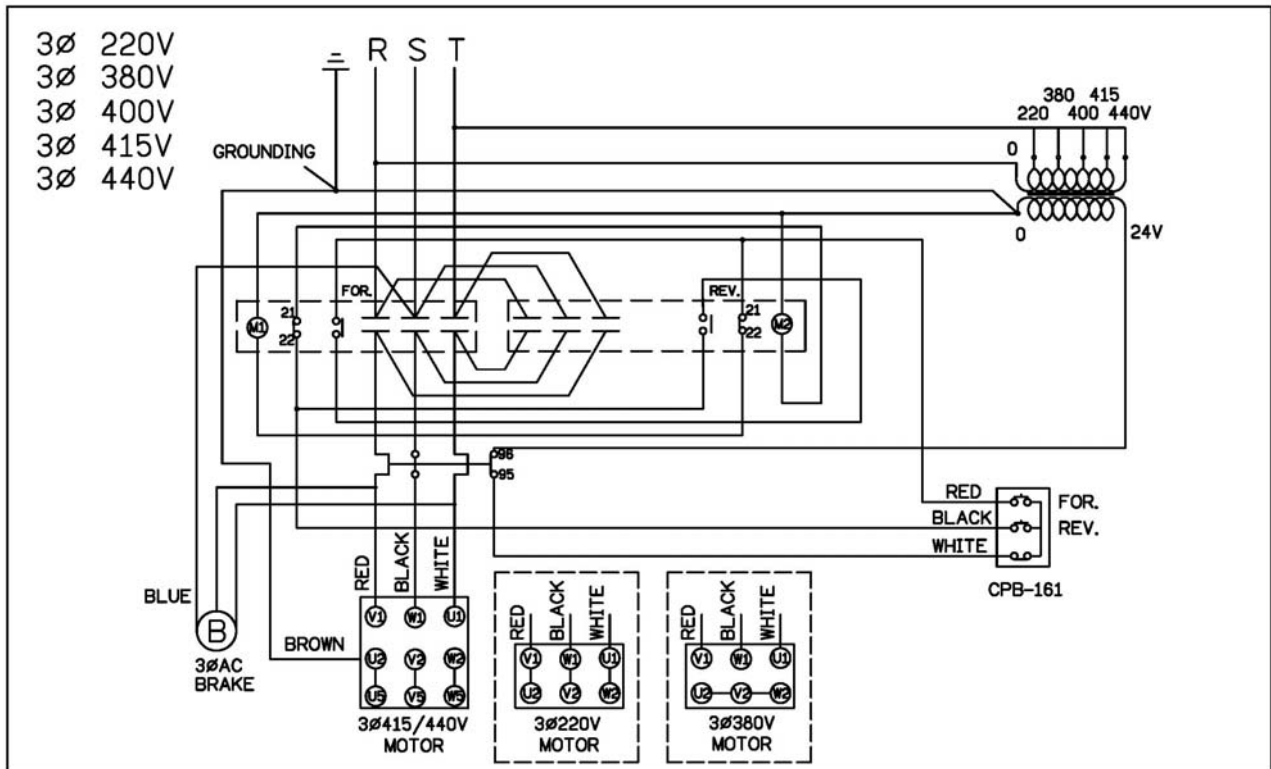

Warning

- The winch is not intended to be used in any manner for the movement or lifting of personnel.
- The lifting capacity shown is based on the top layer of rope on the drum.
- The rope winding on the drum shall remain 5 wraps from the drum.

Parts List

Item No.	Description	Part No.	Qty
1	Motor kit	As arranged	1
2	Motor support rack kit	880723	1
3	Drum kit	880724	1
4	Connect shaft kit	880725	1
5	Tie bar kit	880726	4
6	Gearbox support rack kit	880727	1
7	2 nd stage carrier kit	881576	1
8	Ring gear kit	880730	1
9	1 st stage carrier kit	881577	1
10	1 st shaft kit	880733	1
11	Brake base kit	880625	1
12	Brake kit	As arranged	1
12-1	Brake disc	880626	2
12-2	Brake coil	As arranged	1
13	Brake rear cover	880627	1
14	Wire rope w/hook	880737	1
15	Low voltage control ass'y LV-320	As arranged	1
15-1	Remote control, CPB-161	881047	1
16	Base plate kit	880738	1

Part No. configurations:

Cycle	Voltage	kw x p	Motor	kw x p	Motor
50 Hz	220 / 380	5.5 x 4	880637	3.8 x 6	880641
50 Hz	415 V	5.5 x 4	880638		
50 Hz	440 V	5.5 x 4	880636		

Cycle	Voltage	Brake kit	Brake coil	LV-320
50 Hz	380 V	881345	880648	881826
50 Hz	415 V	881346	880649	881831
50 Hz	440 V	881347	880650	881834

Standard Value for brake coil:

Voltage	220V	380V	415V	440V
Black & Blue wires	28Ω	108Ω	117Ω	126Ω
Black & Red wires	12Ω	48Ω	52Ω	56Ω
Red & Blue wires	15Ω	54Ω	62Ω	70Ω

Winch Assembly

